

Responsive Cohesion in the Form Language of the Aalto Ateliers

Antony Radford

Emeritus Professor of Architecture
School of Architecture, Landscape Architecture and Urban Design
The University of Adelaide, SA 5005 Australia
antony.radford@adelaide.edu.au

Publisher Alvar Aalto Museum
ISSN-L 2323-6906
ISSN 2323-6906

www.alvaraalto.fi
www.alvaraaltoresearch.fi

Abstract

Responsive Cohesion is a kind of relation between 'things' (objects, ideas, people, processes or systems) and other 'things' or contexts, in which cohesion is achieved by the way they respond to each other. This paper outlines a study of responsive cohesion in the form language and form patterns to be found in the designs of Alvar Aalto and his ateliers.



Introduction

This paper outlines a study of the form language to be found in the designs of the ateliers led by the Finnish architect Alvar Aalto (1898-1976) in relation to the concept of responsive cohesion put forward by philosopher Warwick Fox in his book *A Theory of General Ethics* (Fox 2006). The study crosses boundaries of design fields (art, glass, furniture, architecture, urban design and planning) and time, and makes no distinction between realised and unrealised designs, or between exploratory studies and final designs. It includes a sampling of drawings in the Aalto archives, irrespective of whether they were drawn by Alvar, Aino or Elissa Aalto or other studio staff,¹ and extensive examination of buildings and products. The form patterns are taken 'as they are'; the research does not seek to explain their origins, the reasons for their selection or their historical development, although all of these issues are interesting.

Aalto Form Patterns

In a previous paper *Alvar Aalto and the Expression of Discontinuity* (Radford and Oksala 2007), Dr Tarkko Oksala and I sought to identify and analyse Aalto form patterns and discussed the interpretation of Aalto designs. Our work acknowledged and continued from the writings of others about the Aalto form language but had two significant differences. We placed equal importance on all design areas rather than emphasising architecture and we offered a concise and explicit grouping of six recurrent patterns in the form language. These six patterns are:

1. Composite curve, a sequence of arcs and straight lines, or of arcs of different radii.
2. Repetition, a grouping of similar elements or the division of an element into distinct segments.
3. Overlay, an actual or apparent layering of one surface over another surface, often as part of a collage.
4. Offset, a lateral shifting of a line or plane that then continues in the original direction.
5. Divergence, a fan-like spread of elements.
6. Head and tail, a hierarchical organisation of a form with distinct primary elements and adjoining secondary elements.

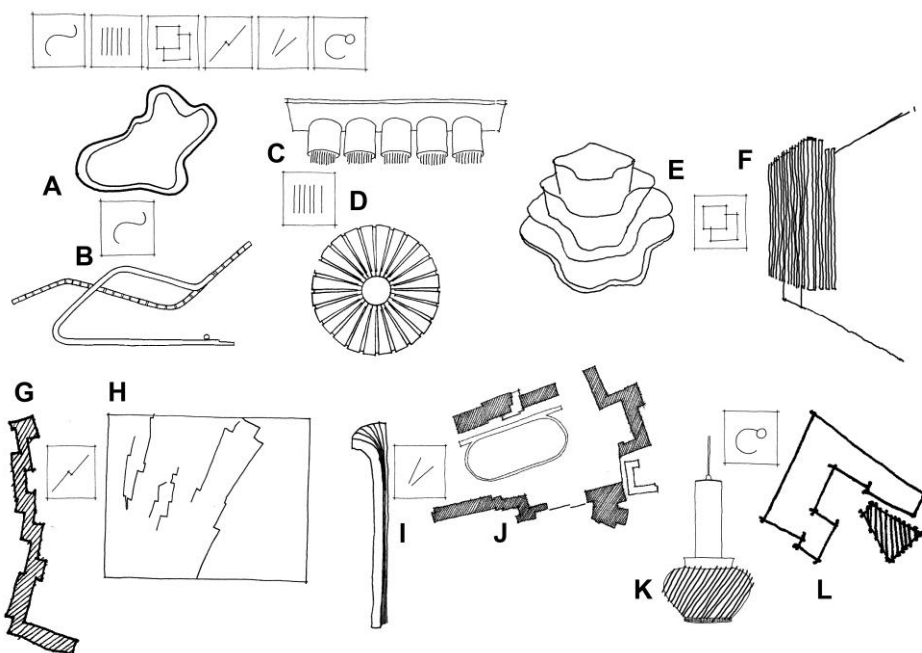

Aalto Form Patterns and Responsive Cohesion

Following from this study, the questions that interest me are:

1. How do the form patterns work together?
2. How is the form language mobilized to respond to environment, production and use?
3. How does the form language relate to the way people respond to the designs?

Stanford Anderson (quoting Aalto's own appreciation of the traditional Karelian farmhouse) notes Alvar Aalto's 'methodical accommodation to circumstance.'

With Aalto, 'accommodation' rarely means the submission of one circumstance to another, but rather the informing presence of contrasting formal moves each making its own accommodation to varying circumstances. There are formal propositions, but accommodation is not forced under some unifying system, whether structural or decorative. The results of such a method appear throughout Aalto's work. (Anderson 2008: 85, 86)

Anderson's observation is compatible with environmental philosopher Warwick Fox's assertion in his book *A Theory of General Ethics* (Fox 2006) that what he terms 'responsive cohesion' is a recurring and universal characteristic of successful natural and cultural systems. He explains responsive cohesion by pointing to extremes of fixed cohesion and dis cohesion. Fixed cohesion refers to fixed, unyielding relationships: dictatorship, inflexible design rules, mandated orthodoxy. Dis cohesion refers to the lack of any relationships: chaos, randomness, anarchy. In neither case is there any responsiveness in the relationships between parts. Responsive cohesion is a third kind of relation, where cohesion is secured through the response of parts to each other to mutual benefit; 'response' comes from the Latin *Respondum*, 'answering to'.

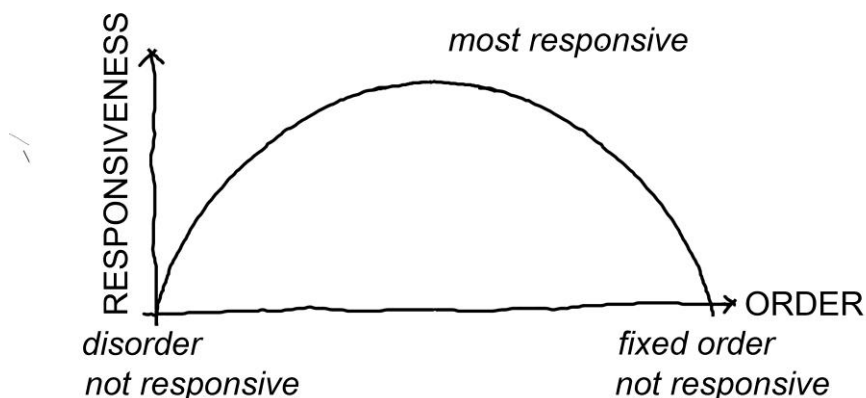

Consider a conversation. If the cohesion is fixed – the conversation proceeds according to a predetermined script or reduces to a monologue – there is no genuine responsiveness between the participants. If there is no cohesion then the contributions to the conversation are random and chaotic, hardly a conversation at all. In a conversation that is marked by responsive cohesion the participants are listening to each other and answering, with no one participant dominating and no set plan. Although the structure is loose, the conversation is meaningful and coherent. This is the best kind of conversation, the cut and thrust of debate where there is attention, insight and inventive but relevant reply.

We can shift this conversation from one between humans to one (metaphorically) between components of a design. The best kind of 'conversation' is one where there is a mutual benefit to each component by the presence of others, their forms 'answering to' each other in lively exchange. We can also think of a 'conversation' between a design and a human, where the human responds to the design and the design appears to respond to or take on the character that is suggested by the human interpretation.

Fox writes that the relational quality of responsive cohesion exists '*whenever the elements or salient features of things can be characterised in terms of interacting (either literally or metaphorically) with each other in mutually modifying ways such that these mutually modifying interactions serve (at least functionally if not intentionally) to generate or maintain an overall cohesive order – an order that 'hangs together' in one way or another*' (Fox 2006: 72). He argues that responsive cohesion is the 'foundational value' in a general ethics, foundational in that it cannot be reduced to more basic values. Ethically, achieving responsive cohesion should be guided by a 'theory of contexts': achieving responsive cohesion with a context is always more important than achieving internal responsive cohesion, although both are to be sought (Fox 2006: 171-2). Fox uses the word 'trumps'. In fact the 'theory of contexts' follows directly from acceptance of responsive cohesion as the foundational value, since this is the most effective way to preserve and promote overall responsive cohesion. For practical purposes the largest context in our world is its biophysical environment (the natural world and its ecosystems) that ultimately sustains all other systems. Therefore, achieving responsive cohesion at a global level trumps all other considerations, so issues like global warming and climate change – the well-being of the biggest context – trump lesser issues. Fox explicitly addresses the built environment (for example Fox 2010) and without venturing far into the field of ethics, I have argued in *Responsive Cohesion as the Foundational Value in Architecture* (Radford 2009) that responsive cohesion is at least instrumentally effective as an overarching principle in design practice.

In design, achieving responsive cohesion with global and local contexts will trump achieving internal responsive cohesion if there are irreconcilable conflicts between them. But design should seek to achieve *both external and internal* responsive cohesion, and not to achieve the former at the expense of the latter or *vice versa*. Anything less is a design failure.

The ideal of responsive cohesion, then, includes but is not limited to the relations between an element of a design and other elements of a design. Looking at Aalto designs with this in mind, I can consider the way in which the form patterns respond to each other and would expect to find a 'lively conversation' between them. Further, I would expect to find that the form patterns are combined in ways that respond to, and add value to, their physical and non-physical contexts.

My methodology is simply to read, observe and interpret with the concept of responsive cohesion in mind.

1. Read the words of scholars. A great deal has been written about Aalto designs, and the interpretations of others stimulate and question my own interpretations.
2. Read the words of members of the Aalto ateliers. Alvar Aalto wrote about design in his early years, much of it collected in Schildt 1997. Two books (Lahti 2001, and Charrington and Neva 2011) have recorded interviews and conversations with his staff and colleagues.
3. Sample designs in physical form. There is no substitute for visiting buildings and viewing art, and viewing or using furniture and lamps.
4. Sample drawings in the Aalto archives. The Alvar Aalto Museum maintains an invaluable collection of drawings and photographs.

For illustration I shall consider two designs that include all six of the Aalto form patterns that I listed earlier in this paper. In the façade of Alajärvi Town Hall form patterns are mobilised to give dignity and prominence to the council chamber, filter daylight through windows and break down the scale of the building to its natural and built contexts. In an external light fitting at TKK the form patterns are used in elements that reflect and filter light to illuminate a walkway and reduce glare. There is a responsive relation between this design and light; the unit functionally improves the quality of light, and the unit is aesthetically enhanced by light when it is operating.

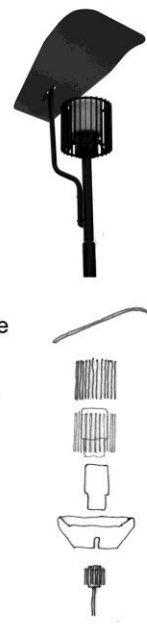
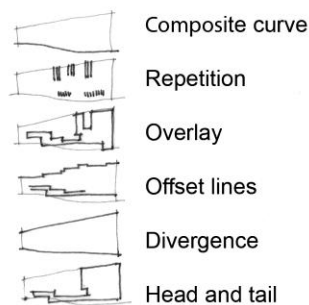
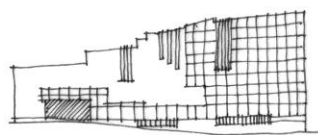

The aim of seeking responsive cohesion with multiple and diverse contexts (or methodical accommodation of circumstance) points to design as trying to make compatible appropriate responses to the diverse objectives of its creation. Fredric Jameson (1994: 168)² refers to a 'lumber room' in which complete and incomplete ideas, technical solutions, references to the past, and half-formed concepts – 'a kind of anthology of disconnected parts and pieces' – find themselves. The designer's task is to create a work in which the contents of the lumber-room appear to be an integrated whole. In the most successful designs the work appears as both an aesthetically and functionally convincing, even inevitable, consequence of all of its disparate origins. An examination of drawings in the Aalto archives suggests that overall forms were decided early and quickly in the design process, but the looseness of their definition (Alvar Aalto himself sketched with a 6B pencil) allowed for their modification and refinement as contexts and relationships were better understood.



Turning to the human response to this form language, consider a most evocative place: the courtyard at Aalto's own summer house ('experimental house', 1953) at Muuratsalo. It is both monumental and rustic, apparently still unfinished and ruined, formal and playful, open and closed. Pallasmaa (1998: 86) attributes the emotional impact of Aalto's buildings to suggestions of shelter, protection, comfort and togetherness. In *Alvar Aalto and the Expression of Discontinuity* (Radford and Oksala 2007) we argue that emotional impact is also linked to a correspondence between the ambiguous suggestion of both incompleteness and ruination in Aalto's buildings and our human condition between birth and death. Ambiguity is the essence of the house, the 'hinting at' rather than the 'prescription of' ways of interpreting space and form. At a different scale, consider two white and clear glass Aalto vases. I can see outlines of a frosty lake, melting fragments of ice, spreading algae, and a drop of milk. I can see responsive cohesion in the relations between fragments of the designs, and note the way light is reflected and refracted by the glass surfaces to generate new patterns that add to the aesthetic pleasure. Ambiguity helps a human experienter to establish a personal responsive cohesion with the place or object.

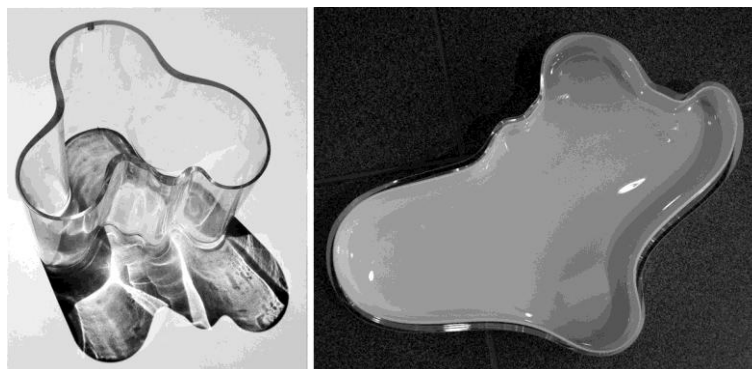

Aalto Form Patterns and the 21st Century

The form of an Aalto vase has been appropriated and adapted in recent years to serve as a silicon ice cube mould, an aluminium napkin ring, a wooden tray and pot mat, and a small carved wood device to slot over the rim of a pot to raise its lid. All these are evidence of the ability of the form language to respond to different contexts. Not all adaptations match the aesthetic appeal of the original vases. Consider the addition of a glass votive candle holder in the Iittala collection of designs 'inspired by Alvar Aalto'.

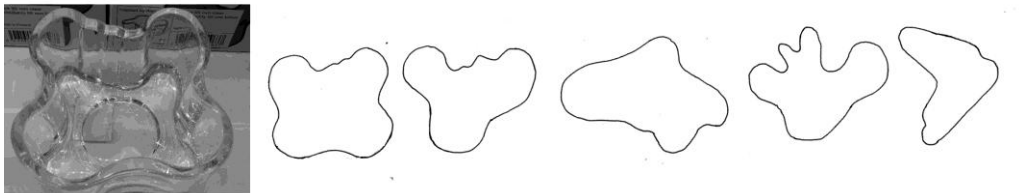

The form patterns in this new product are almost literal reproductions of elements from the famous Savoy vase, including the 'offset line' squiggle that disturbs the smooth 'composite curve' on one side. But the new product shifts towards the fixed cohesion end of the scale between fixed cohesion and dis cohesion, towards biaxial symmetry and a reduced sense of conversation between the projections. While the design only claims to be 'inspired by Alvar Aalto' and may function well, it demonstrates the difficulty of making distinguished new designs in the same language.

The design of a household product is hardly a major issue in today's world. For most designers, a short list of more significant issues might include sustainability, urbanism, identity, digital design and collaborative design. I believe that the characteristics of the Aalto form language are well suited to responding to all of these issues, although that does not deny that other form languages might perform equally as well, or better, or mean that its reproduction by other designers is necessarily desirable. The Aalto form language, though, can boast a track record of survival and adaptation, and offers a rich and well-documented body of work in which to explore questions of how a set of form patterns operates in a form language that effectively responds to environmental and cultural contexts.

I propose four ways in which the Aalto form language is relevant in the twenty-first century.

1. Aalto designs exemplify a well-formulated design language that combines economy of forms with expressive range. The Aalto form language has a small number of basic patterns, but these are mobilized to make a rich variety of designs in scales that range from a vase to a town centre. Over time, designs and their details (doors and windows, eaves, light fittings, built-in furniture) were reworked for each new situation – a reaffirmation and/or refinement of the design. As a model for the 21st century, their strong parts and loose wholes character facilitates flexibility and adaptability.³

2. Aalto designs exemplify the integration of responses to multiple design contexts and objectives, including function, technology, manufacture, environment, location, economics and humanity. In Aalto designs form is not “forced through”, it is adapted to fit its contexts and circumstances. The character of the form language allows this integration and adaptation to changing needs. As a model for the 21st century, the form language can respond to the demands of environmental, cultural and economic sustainability.
3. Aalto designs have demonstrated lasting appeal to humans. This appeal is not restricted to a design elite; Aalto vases are sold in Finnish supermarkets. The appeal is related to the evocative character of the design forms and particularly an ambiguity between incompleteness and ruination that reflects the human condition. In architecture and urban design the appeal also relates to an attitude of respect for humans, for example in the way people move through a building, the careful balance between appropriate dignity and homely informality, and a gentleness and softness in forms that offer ‘accepting’ environments. Aalto theatres, churches, town halls and opera houses support a sense of occasion without oppression. As a model for the 21st century, the form language demonstrates the possibility of simultaneously achieving popular and expert appeal that goes beyond short-term fashion.
4. Aalto designs both reflect and enable a mode of design team working that respects the expertise of others (engineers and craftspeople, most notably in the design of furniture and lamps) and facilitates collaboration because the team knows and ‘speaks’ the design language. This is different from the common notion of design by committee, because members of most committees do not ‘speak’ the same design language. While Alvar Aalto was unquestionably the most inventive and fluent ‘speaker’ of the Aalto form language and naturally led the team, the quantity and consistency of the work would have been impossible without his fellow ‘speakers’. Prototypes were made of small items (lamps and furniture) and large physical models were made of large items (buildings and urban design projects) to test the designs. Innovation within this design language won competitions, while consistency won repeat clients. As a model for the 21st century, it is a mode of working that can be re-interpreted for contemporary parametric and rule-based digital design systems, where professional disciplines share digital models and design models are linked directly with pre-production prototypes and numeric-controlled production systems.⁴

Relevance in the 21st century lies in these characteristics of the Aalto form language, not in the particular repertoire of the Aalto form patterns. The most fundamental of these characteristics is the potential to achieve internal responsive cohesion in designs and external responsive cohesion between designs and their contexts.

Daniel Herwitz (2008: 165) observes that “You bring from the experience of a work a satisfaction that comes from it. You just have to work out the why and the wherefore!” Like many others, I have always found great satisfaction in Aalto designs of all kinds. This study can be characterized as a personal desire to understand the why and the wherefore.

Acknowledgements

I thank The Alvar Aalto Museum for making their archives available to researchers. I acknowledge the contribution of Tarkko Oksala in the identification and analysis of Aalto form patterns, and thank him and others including Pellervo Oksala, Esa Laaksonen, Markku Lahti, Warwick Fox, Isis Brook and Gareth Griffiths for insights and challenges that have informed my interpretation of Aalto and/or philosophy. Responsibility for that interpretation is, of course, my own.

¹ A recent book (Charrington and Nava 2011) provides insights into the way the Aalto office operated and the responsibilities of the architects in the office.

² This appears in a discussion on the work of architects Rem Koolhaas and Peter Eisenman. Jameson notes Pierre Macherey's (1966) book *Towards a Theory of Literary Production* as providing a model for reading work that stems from multiple origins.

³ 'Loose wholes and distinctive parts' is a strategy advocated by the Japanese architect Fumihiko Maki (2011).

⁴ See Bruton and Radford 2012 for a critical view of digital design that emphasizes the importance of rules, patterns and response to circumstances.

Bibliography

- Anderson, S. (2008) 'Thinking in Architecture', *ptah8 – building, designing, thinking*, pp. 74-88.
- Bruton, D., and Radford, A.D. (2012) *Digital Design: A Critical Introduction*, London: Berg.
- Charrington, H., and Nava, V. (eds.) (2011) *Alvar Aalto: Mark of the Hand*, Helsinki: Rakennustieto.
- Fox, W. (2006) *A Theory of General Ethics: Human Relationships, Nature, and the Built Environment*, Cambridge, Mass: MIT Press.
- Fox, W. (2010) 'Warwick Fox, 'Developing a General Ethics (with Particular Reference to the Built, or Human-Constructed, Environment)', in David Keller, ed., *Environmental Ethics: The Big Questions*, Malden, MA: Wiley-Blackwell, pp. 213-220.
- Herwitz, D. (2008) *Aesthetics: Key Concepts in Philosophy*, London and New York: Continuum.
- Jameson, F. (1994) *The Seeds of Time*, New York: Columbia University Press.
- Lahti, L. (2001) *Alvar Aalto - Ex Intimo: Alvar Aalto through the Eyes of Family, Friends and Colleagues*, Helsinki: Building Information Ltd.
- Macherey, P. (1966) *Towards a theory of literary production*, translated by G. Wall, London, Boston: Routledge and Kegan Paul.
- Maki, F. (2011), Presentation at *Natural Artifice*, Annual Conference of the Australian Institute of Architects, Melbourne, Australia, 15 & 16 April.
- Pallasmaa, J. (1998) 'Image and Meaning', in Pallasmaa, J., ed., *Alvar Aalto: Villa Mairea*, Helsinki: Alvar Aalto Foundation/Mairea Foundation, p86.
- Radford, A.D. (2009) 'Responsive Cohesion as the Foundational Value in Architecture', *The Journal of Architecture*, 14(4): 511-532.
- Radford, A.D. and Oksala, T. (2007) 'Alvar Aalto and the Expression of Discontinuity', *The Journal of Architecture*, Vol 12: Number 3: pp.257-280.
- Schildt, G. (1997). *Alvar Aalto in His Own Words*, New York: Rizzoli.